

Hannover CR 67

Operating Instructions

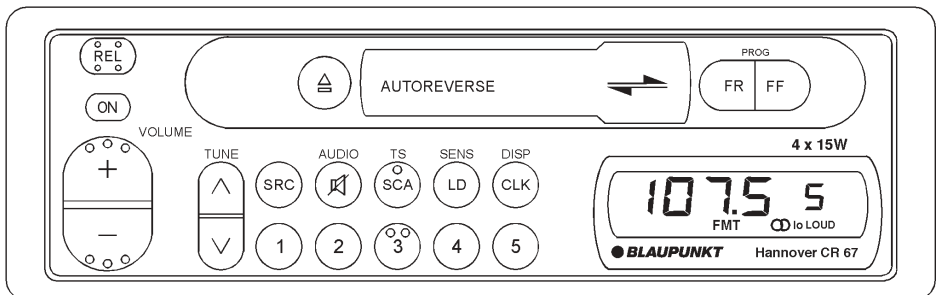

Congratulations on your purchase of this Blaupunkt Cassette Receiver.

Table of Contents

English

Features	3
Traffic Safety and Precautions	3
Detachable Face	4
Electrical Connections and Installation	5
Installation	7
Maintenance	9
Specifications	10
Location of Controls	11
Instructions - General Operation	12
Audio Operation	13
Radio Operation	14
Cassette Tape Player Operation	15

Features

Congratulations on your purchase of this Blaupunkt Cassette Receiver. Its Codem III FM/AM Tuner and Autoreverse Cassette Tape Player mechanism provide the ultimate in sound reproduction.

- Codem III Tuner Features:
 - Multipath Management
 - ASU Electrical Impulse Noise Reduction
 - Superior AM Frequency Response
 - 15 FM/5 AM Presets, Including 5 FM & 5 AM Travel Store Presets
 - Station Scan
 - Local/Distant Seek & Manual Tuning
- Cassette Tape Player Features
 - Auto-Reverse Cassette Mechanism
 - True Fast-Forward/Rewind
 - Hard Permalloy Tape Head
 - Radio Monitor with Radio Preset Access
- Audio Features:
 - 15 Watts x 4 Channel Integrated Amplifier
 - Adjustable Maximum Turn-On Volume
 - Bass, Treble, Balance and Fader Control
 - Loudness Button
 - Mute Button
- Other Features:
 - Partially Detachable Face
 - Green Illumination
 - Display Priority Control
 - Temporary Display Change Control
 - Clock/Ignition-Off Clock Recall
 - 179 x 50 x 150 mm
DIN/ISO Chassis
 - Detachable Wire Harness (ISO)
 - Snap-In DIN Sleeve & Mounting Hardware

Your unit's detachable front faceplate makes the unit useless to would-be thieves.

*Designed, Engineered and Manufactured
By Blaupunkt.*

Traffic Safety and Precautions

- Do not adjust your unit in difficult driving conditions that demand your full attention.
- As the driver of a motor vehicle, it is your responsibility to pay attention to the traffic situation at all times. Never use your unit in a way that could distract you.
- Always make sure that you are still able to hear any warning signals coming from outside of the vehicle, such as police or fire engine sirens, so that you can react accordingly.
- If your vehicle was parked in direct sunlight resulting in a considerable rise in temperature inside the vehicle, allow the unit to cool off before operating your unit.
- You are cautioned that any changes or modifications not expressly approved in this manual could void your warranty.

Detachable Face

Detaching & Attaching the Face:

The face of this unit can be detached and taken with you to prevent it from being stolen.

Detaching the Face:

Press the REL (Release) Button and detach the face by gently pulling it off as illustrated.

Note: Do not pull it straight out from the chassis. Be sure not to drop the face when detaching it from the chassis.

Attaching the Face:

Apply the right hand side of the face to the chassis by sliding (part B) of the face to (part A) at the front of the chassis. Gently push the left side of the face against the front of the chassis until it snaps into place.

Note: Make sure that the face is inserted right side up. Do not press against the display window. Do not press hard against the face when attaching it to the chassis, it may be easily attached with gentle pressure. Do not expose the face to direct sunlight, heat sources such as hot air ducts or leave it in a humid place. Never leave it on the dash board of a vehicle parked in direct sunlight, where there may be a considerable rise in temperature inside the vehicle.

Affixing Faceplate For Retail Display:

The faceplate can be affixed to the unit's chassis, which is desirable for a retail display, for example. **This should only be done in situations where the unit can be accessed from behind the mounting surface. Once the faceplate is affixed, the release keys cannot be used to remove the chassis.**

To affix the faceplate:

Insert the black bolt into the hole at the left front of the top of the radio. See* below.

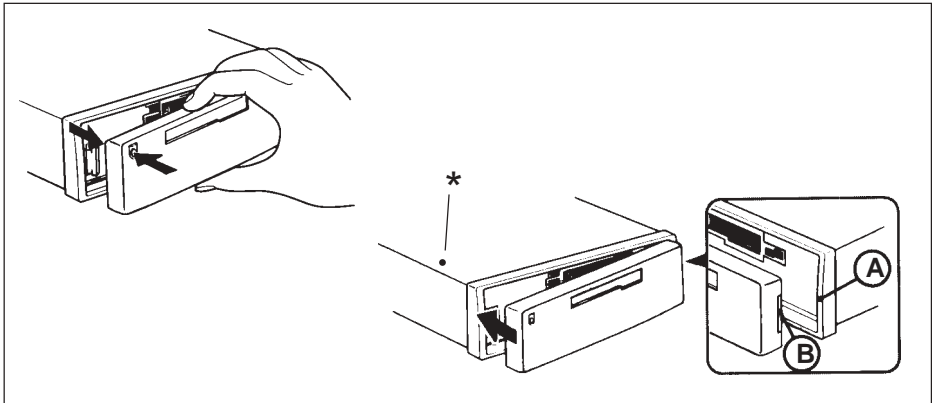

Electrical Connections and Installation

Please carefully read all of the instructions before you begin. Carefully follow all instructions. You'll be glad you did!

GENERAL RECOMMENDATIONS

- If you're not confident that you can install the unit correctly, have it installed by a qualified Blaupunkt installation technician.
- Use this unit only with negative ground 12 Volt (11-16 Volt) direct current (DC).
- Be sure to detach the faceplate before you start to connect or install the unit.
- We recommend making and testing all electrical connections before installing the unit. Connect the leads (wires) according to instructions and diagram below.

ELECTRICAL CONNECTION INSTRUCTIONS

1. Disconnect the vehicle battery's negative terminal before making connections.
2. Connect the speakers and/or external amplifiers (if you have any) following the guidelines in the SPEAKER CONNECTION section below.
3. Connect the blue (trigger output) lead to the antenna motor trigger input terminal (if you have one). The total amperage required of the blue lead must not exceed 300 mA. DO NOT connect the blue lead to the antenna's power supply input.
4. Connect the black (power ground) lead to a grounded metal part on the vehicle. We recommend grounding all audio system black ground leads (head unit, external amplifier, etc.) to a common grounding point, preferably a non-painted surface under the instrument panel.
5. Connect the yellow (constant power) input lead to a source of constant battery power, preferably a terminal to an appropriate slot in the fuse box.
6. Connect the red (turn-on power) input lead only after the other leads are connected. Be sure to connect the red lead to a positive (+) 12 Volt power terminal that is energized only when the ignition key is set to the on position or accessory position.
7. Cover the ends of any unused leads with electrical tape. This will prevent them from touching the vehicle or each other and causing a short-circuit and damage to the radio or vehicle.
8. Reconnect the vehicle's battery.
9. Verify that no fuses have blown.
10. Plug the harness into the unit.
11. Attach the faceplate and test the unit.

Once the connections have been successfully made, you can begin to mount the unit.

SPEAKER CONNECTIONS

- You can connect a speaker (regular, co-axial or tri-axial speakers or component speaker system, all hereafter referred to simply as “speaker”) to each of the units’ four pairs of speaker leads.

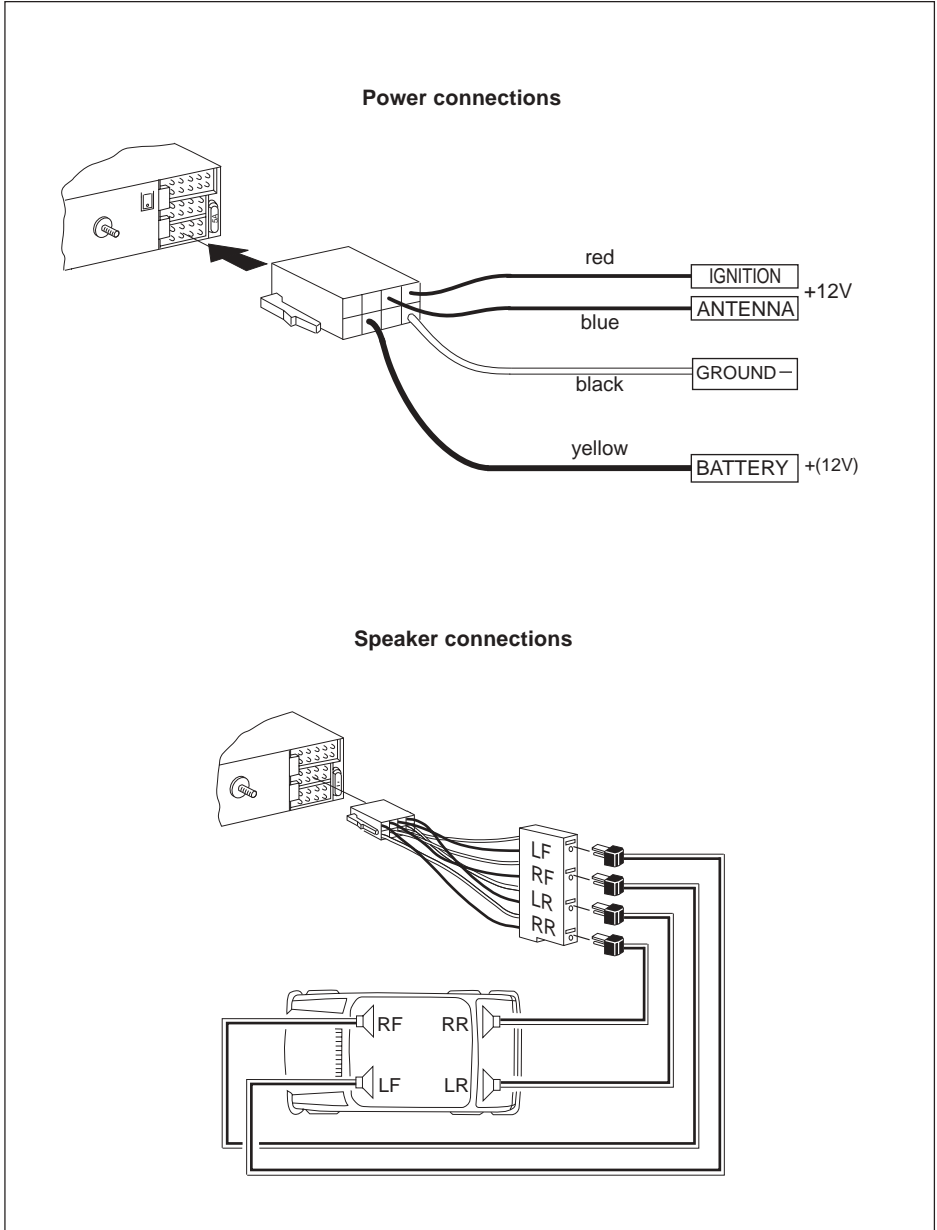

Installation

Recommendations

- Carefully choose the mounting location so that the unit won't interfere with normal driving.
- Avoid mounting locations where the unit would be subject to high temperatures, such as from direct sunlight or hot air from the heater, or where it would be subject to dust, dirt or excessive vibration.
- The illustration below shows a typical installation, however, you may need to adjust the installation, depending on the unit. If you have questions or need additional installation hardware, consult your Blaupunkt dealer.
- Make sure the unit is firmly anchored (preferably at both front and back) and does not vibrate.

Mounting Hardware

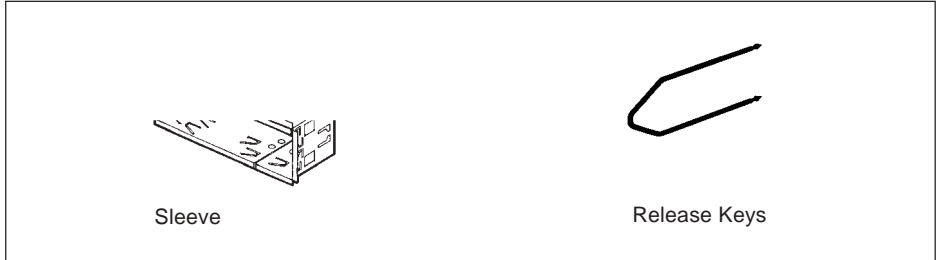

Mounting The Unit in Most Dashboards

- 1 Install the Sleeve in the dashboard.
- 2 Select and bend the appropriate tabs to hold the sleeve firmly in place.

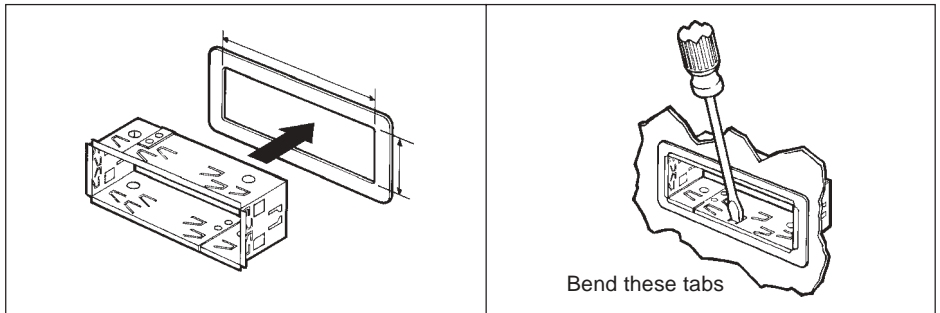

Mounting the Unit in a Japanese Car

You may have difficulty mounting this unit in some Japanese cars that have ISO mounting features.

In this case, consult your Blaupunkt dealer.

- 1 Run a blade along the slits on the back of the front trim ring, unscrew the two side screws, and separate it from the unit. Save the trim ring and related hardware in case you ever want to install the unit in another vehicle.
- 2 Use the vehicle's own mounting hardware to attach the unit.

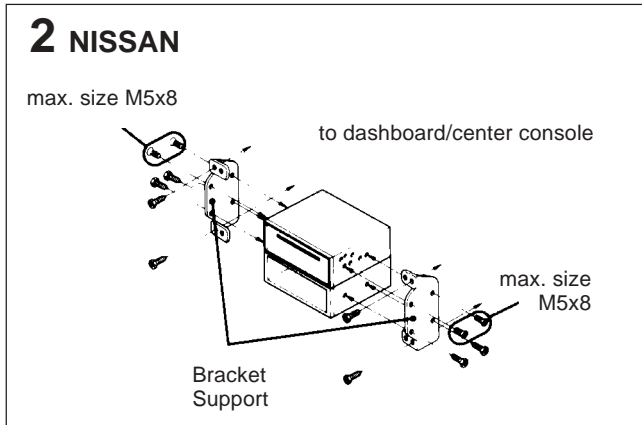
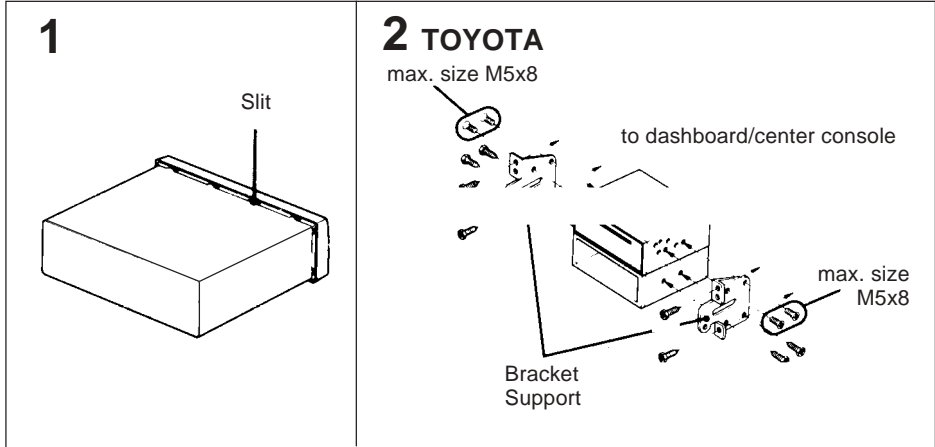

Maintenance

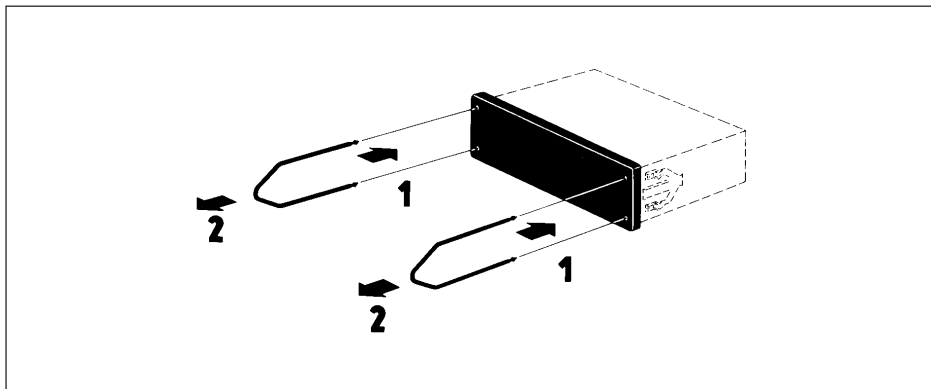

Removing the Unit

Use the Release Keys as shown below. Keep them in a safe place in case you need them in the future.

Fuse Replacement

When replacing the fuse, be sure to use one with the correct amperage, which will be stated on the fuse case. Never use a fuse that has a stated amperage exceeding the one supplied for this unit, as this could cause malfunction and serious damage to the unit.

Specifications

Audio Power Specifications

Power Output and Total Harmonic Distortion: 10 watts per channel minimum continuous average output into 4 ohms, 4 channels driven, from 30-15 000 Hz with no more than 1% total harmonic distortion.

Other Specifications

Tuner

FM

Tuning Range: 87.5 - 108 MHz
FM Mono Sensitivity: 1.3 μ V

Selectivity: 80 dB at 400 kHz
Signal-to-Noise Ratio: 65 dB (stereo), 70 dB (mono)
Harmonic distortion at 1 kHz: 0.7% (stereo), 0.5% (mono)
Separation: 30 dB
Frequency Response: 30-15.000 Hz \pm 3 dB

AM

Tuning Range: 531 - 1.602 kHz
Signal-to-Noise Ratio: 50 dB
Frequency Response: 30-5.000 Hz

Audio

Speaker Impedance: 4-8 ohms
Maximum Amp Power: 4 x 15 Watts (at 4 ohms)
RMS Power: 4 x 10 Watts (at 4 ohms)
Bass Control: \pm 10 dB by 100 Hz
Treble Control: \pm 10 dB by 10 kHz
Loud: + 8 dB by 60 Hz, + 2 dB by 8 kHz

Cassette

Signal-to-Noise Ratio: 55 dB
Tape Wow and Flutter: 0.3 %
Tape Frequency Response: 30-16.000 Hz

General

Dimensions (w/o projecting parts/controls): 179 x 50 x 150 mm
Mass: Approx. 1.4 kg
Power Requirement (neg. grnd.): 12 V DC car battery (11-16 V DC allowable)
Operating Temperature: -10 C to 50 C
Supplied Accessories:

- Unit
- Faceplate
- Wire Harness
- DIN Sleeve
- Mounting Hardware

Design and specifications subject to change without notice.

Location of Controls

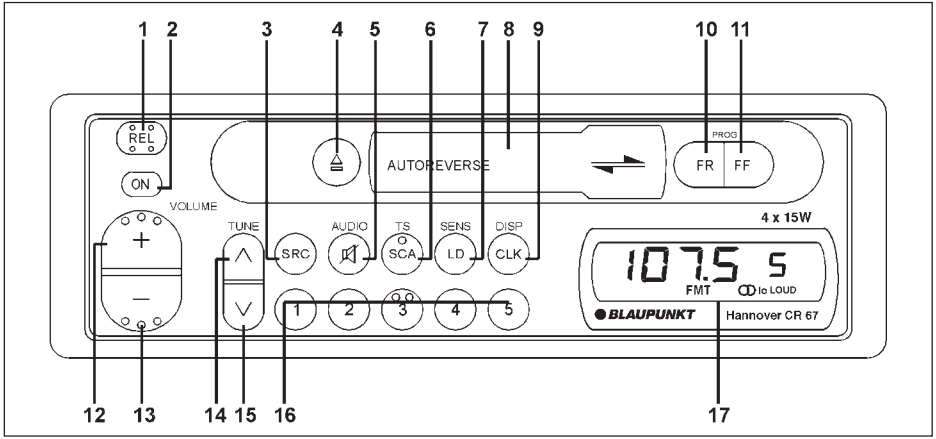

- | | |
|--|--|
| <ul style="list-style-type: none"> 1. REL (Release) Button 2. ON (Power) Button 3. Source (and Radio Band) Select 4. Cassette Eject 5. Mute/Audio Button/Clock Adjust:00 6. SCA (Scan) TS (Travel Store) 7. LD (Loudness)/ SENS (Tuning Sensitivity) 8. Cassette Insertion Slot 9. CLK/Display Change 10/11. Tape Program Change (reverse) 10. Fast Rewind 11. Fast Forward 12. + Button Volume + Bass + Treble + Balance Left Fade to Front | <ul style="list-style-type: none"> 13. - Button Volume - Bass - Treble - Balance Right Fade to Rear 14. ^ Button Seek and Manual Tunin Clock Hours 15. v Button Seek and Manual Tuning Clock Minutes 16. FM/AM Presets 17. Display |
|--|--|

Instructions — General Operation

See **Traffic Safety & Precautions** on page 3.

“Press” means a momentary press of less than 1/2 second. All presses requiring more than 1/2 second are followed by beep.

“Time Out” When additional button presses are anticipated to complete a procedure, the unit will automatically exit the procedure after 4 seconds of inactivity.

Ignition-Off Clock Recall / Turning Unit On

Vehicle ignition must be on. To turn unit on, press ON Button (2) or insert a tape.

Ignition-On / Turning Unit Off

Press the ON Button to turn the unit off.

Release for Detachable Faceplate

Push REL to detach face. Already-inserted cassette remains in unit. Current settings and source mode are stored. If power was not switched off before face removed, unit will automatically power-on when face is reattached.

Power (ON) On/Off

When ignition on, press ON or insert a disc to turn unit on. Last-used source becomes active, unless unit is turned on by inserting tape, in which case tape player becomes active.

Power Off

Press ON to turn unit off. Unit stores current settings for source, station or track, etc. Antenna/amplifier trigger wire shuts off voltage. (If faceplate still attached, display switches to clock.)

Setting the Clock

Turn the unit on. Press the CLK Button for four seconds until the clock starts blinking. (The display will change after two seconds. Ignore this and continue to hold for two more seconds.) Once the clock starts blinking, Press the \wedge to set the hour, and press the \vee Button to set the minutes. (To change the minute indicator to the nearest hour (:00), you can press the MUTE Button. Press the CLK Button again to activate the clock.

Changing the Information Displayed

You can temporarily change the information shown in your unit's display. You can also select which information has “display priority” and is shown in the display except for moments when adjustments are made.

- To change the display priority, press the CLK Button for two seconds. The display priority changes. The display priority choices are clock or radio frequency / “TAPE”.
- To change the display temporarily, press and release the CLK Button to access the desired information.* After *four* seconds, the display changes back to the priority information.

Source (SRC)

Use SRC to select source - AMT, FM1, FM2, FMT or cassette (if already inserted).

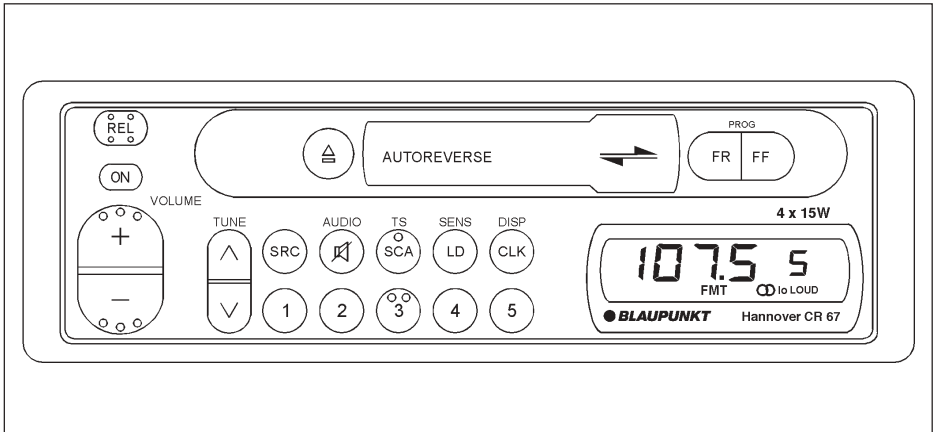

Audio Operation

Volume Control Buttons (+/-)

Press + and - to increase/decrease volume from 0 to 63, in increments of 1.25 dB/step. Volume control is accessible from all modes except Bass, Treble, Balance and Fade modes.

Adjustable Maximum Turn-On Volume

First adjust the volume to the (maximum) volume level desired when the unit is turned on. Press and hold the PWR Button for more than two seconds. The unit turns off and the turn-on volume level is memorized. When the unit is turned on, the volume will be at the memorized level, even if the unit was turned off while the volume was at a higher level. However, if the volume is turned off when the volume level is lower than the stored Turn-On volume level, the volume will be at the lower level when the unit is turned back on.

Mute

Press Mute to temporarily reduce volume by 20 dB. "MUTE" appears. Mute is terminated by pressing any button.

Bass, Treble, Balance and Fade

Press Mute/AUDIO for more than 1/2 second to access Bass. Subsequent presses access Treble, Balance and Fade modes.

Bass - Adjust from +7 to -7 at 2 dB/step using + to increase bass, - to decrease.

Treble - Adjust from +7 to -7 at 2 dB/step using + to increase treble, - to decrease.

Balance - Adjust balance from 9 (all the way left) using + to -9 (all the way right) using -. Adjust fader from 9 (sound only from the front) using + to -9 (sound only from the rear) using -.

Loudness (LD)

Press LD to increase sound of low and high frequencies. LOUD icon appears. To cancel, press LD again.

Radio Operation

Last Station Memory

Each FM bank and AM band has its own last station memory which holds last-tuned frequency for that band or bank irrespective of whether that frequency is stored into a preset.

Selecting Bands

Press SRC as needed to access FM1, FM2, FM3/FMT, AM/AMT banks.

Seek Tuning

Press \wedge or \vee to seek next receivable frequency. Tuning stops at frequency that fulfills sensitivity requirements predetermined by sensitivity set through SENS/LD button.

Tuning Sensitivity (SENS)

Press SENS/LD for more than 2 seconds to switch between local (Lo) and distant search sensitivity.

Radio Reception Hints

- When listening to weak or distant AM stations, adjusting the Treble to minimum (-7) will reduce noise and improve sound.
- In general, set SENS to DX if in rural areas or where stations tend to be weak and distant, and to LO when in metropolitan areas or where stations tend to be strong and local.

Stereo Symbol

Stereo symbol turns on if a stereo station with an incoming signal of at least 20 dB μ V is received. The unit gradually switches between mono to stereo automatically.

Manual Tuning

Press \wedge or \vee for more than 1/2 second and frequency will go one channel/step in direction pressed. Press and hold causes continuous manual tuning. Unit returns to seek tuning mode after 4 seconds or after storing a station on a preset.

Preset Station Storage

After tuning desired frequency on desired band, press and hold a Preset Button for more than 2 seconds to store current frequency. Audio is muted during storage, preset number appears, and beep acknowledges storage.

Preset Station Selection

Press desired Preset Button.

Travel Store

In any FM Bank, press SCA/TS for 2 seconds to activate FM Travel Store. (In AM Bank, press it for 2 seconds to activate AM Travel Store.) TS appears. Beginning at the bottom of the band, TS stores five relatively strong stations and returns to preset 1. Pressing any tuning-related button cancels search operation.

Station Scan Tuning

Press SCA. Frequency blinks (along with preset number if appropriate) during scanning. Unit stops at receivable stations for 4 seconds. Unit continuously scans until user stops scan by pressing SCA, another tuning button or SRC.

Cassette Tape Player Operation

Tape Playback:

- Insert cassette into Cassette Door. (Note: Make sure that the side of the cassette exposed is facing right and that all slack has been removed from the tape prior to insertion.)
- If ignition switch is already in "on" or accessory position, insertion of cassette will turn unit on. If unit already turned on, cassette insertion will override other audio source, such as radio. "LOAD" appears for 2 seconds. Cassette play will begin, and the display will indicate which tape program is in use, "1" or "2".
- The tape will continue to play until ejected, SRC button pressed, or unit turned off.

Ejecting The Tape

Press the eject button completely towards the face of the unit. The tape will eject. If unit is turned on, EJ will appear in the display for 2 seconds and the last-heard radio station will play.

Tape Program Change

- Automatic Change (Autoreverse): When the end of the tape is reached, the unit will automatically reverse direction and play the other side of the tape.
- Manual Change: To manually reverse tape direction, press both PROG (program) Buttons (FR & FF) at the same time.
- The change in direction and in tape program will be confirmed in the display ("1" or "2").

Fast Winding

- To Fast-Rewind the tape, press the FR Button. Tape rewinds and ◀ blinks in the display.
- To Fast-Forward the tape, press the FF Button. Tape fast-forwards and ▶ blinks in the display.
- To stop fast-winding, press the other fast winding button, FR or FF.

Radio Monitor

During tape winding, the radio will play the most-recently heard radio frequency. All frequencies stored on the current bank of preset stations are accessible during fast winding.



Bosch Group

**Jalan Pemimpin
38C - 38D Singapore 577180**

**Robert Bosch (Aust) Pty Ltd
P.O. Box 66 Rosebank MDC
Clayton Victoria 3169
Australia**

**Tahiti Sound
B.P. 3793 Papeete Tahiti 98713
French Polynesia**

**Jebsen & Co. Ltd
(Consumer Products Division)
28F Caroline Centre
2-38 Yun Ping Road
Causeway Bay
Hong Kong**

**Jalan Let. Jen, Soeprapto 9A
Jakarta Pusat 10640
Indonesia**

**Motor Industries Co Ltd
Hosur Road
Adugodi
Bangalore 560 030
India**

**Robert Bosch K. K.
Automotive Parts Division
9-1 Ushikubo 3-Chome
Kohoku-ku
Yokohama 223
Japan**

**Robert Bosch (SEA) Pte Ltd
8A Jalan 13/6
46200 Petaling Jaya
Selangor Darul Ehsan
Malaysia**

**Robert Bosch (Aust) Pty Ltd
New Zealand Branch
14-16 Constellation Drive
Mairangi Bay, Auckland
New Zealand**

**Robert Bosch Inc.
Zuellig Building
1200 Makati City
Sen Gil Puyat Ave
Metro, Manila
Philippines**

**Manhow Trading Co. Ltd
36 Wu Chuan Road
Wu-Ku Industrial Park
Taipei Hsien Taiwan, ROC**

**Robert Bosch Ltd
11th Floor Liberty Square
287 Silom Road
Bangrak
Bangkok 10500
Thailand**

Copyright 1996 by the Robert Bosch Corporation

No portion of this work may be reproduced in any form without the written consent of the Robert Bosch Corporation.

K7/VKD 8 622 400 940 (GB)